

PIX-Belt Tension Tester



Proper belt tension is essential for optimum power transmission and also for the life of the belt. To ensure optimum V-belt drive operation, it is recommended to check the tension in the belts by measuring the deflection force value (N) with the help of a tension measuring device. Belt tension in most of the drives can be checked with adequate reliability by means of PIX Belts Tension Tester.

Tension Measurement Procedure

1. Measure the span-length of the Belt in mm. (refer below sketch drawings)
2. Tie a string or a thread on the two pulleys along with the length of the Belt and mark the center of the span on the Belt.
3. Calculate 1.5% of the span (say 'x') for Belt length less than 1000 mm and 1.0% of the span for Belt length more than 1000 mm. Adjust lower ring on the tension tester on the millimeter scale to coincide, "x" mm with the lower side of the ring. Adjust lower side of the upper ring at 0.00 N.
4. Place tension tester at the center of the span of the Belt. Apply force with the help of tension tester perpendicular to the span, till the lower surface of the lower ring touches the string.
5. Read the deflection force value (N) on the Newton scale by taking reading at the lower side of the upper ring.
6. Compare the deflection force value (N) with the values given in the Table 'A'. The deflection force value (N) should lie between the minimum and maximum values given in the Table 'A'. (Next page)
7. Deflection force less than the minimum recommended value in the range indicates an under-tensioned drive & deflection force higher than the maximum recommended value indicates an over-tensioned drive

Important

1. For new Belts the deflection force value (N) should be kept at maximum.
2. Maximum deflection force value (N) is recommended for pulsating & shock loads.
3. It is recommended to re-check the Belt tension after approximately 24 hours of running and adjust the tension, if necessary.

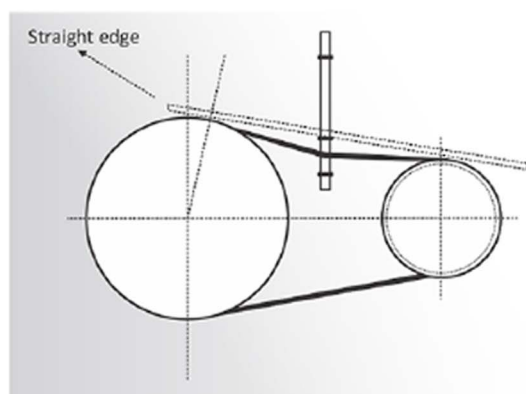
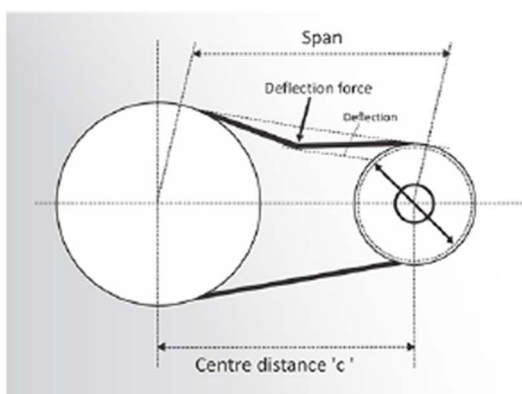

Technical Specification

Deflection force required for measuring tension in V-Belt drives							
Cross Section	Smaller pulley diameter (mm)	Condition1			Condition2		
		Deflection@1% of span, if span length is more than 1000mm			Deflection@1.5% of span, if span length is less than 1000mm		
		Required deflection force 'F' at the centre of span for Belt speed			Required deflection force 'F' at the centre of span for Belt speed		
WRAPPED - CLASSICAL Belts							
		0 m/s to 10 m/s Range (N)	10 m/s to 20 m/s Range (N)	< 20 m/s Range (N)	0 m/s to 10 m/s Range (N)	10 m/s to 20 m/s Range (N)	< 20 m/s Range (N)
Z	50-100	4-6	4-5	3-4	5-8	5-7	4-5
	100 & above	6-9	6-7	5-6	8-12	8-9	7-8
A	71-140	8-12	7-10	6-8	11-16	9-13	8-11
	140 & above	12-18	10-14	8-12	16-24	13-19	11-16
B	112-200	16-24	13-19	10-16	21-32	17-25	13-21
	200 & above	24-35	19-29	16-24	32-47	25-39	21-32
C	180-400	31-46	26-38	20-31	41-61	35-51	27-41
	400 & above	46-70	38-58	31-46	61-93	51-77	41-61
D	315-600	62-90	52-76	42-62	83-120	69-101	56-83
	600 & above	90-134	76-115	62-90	120-179	101-153	83-120
E	450-915	108-160	90-137	73-109	144-213	120-183	97-145
	915 & above	160-240	137-205	109-160	213-320	183-273	145-213

WRAPPED - WEDGE / NARROW Belts							
SPZ / 3V	63-95	8-12	7-10	6-9	11-16	9-13	8-12
	95 & above	12-17	10-16	9-14	16-23	13-21	12-19
SPA	90-140	14-20	12-17	10-14	19-27	16-23	13-19
	140 & above	20-31	17-26	14-22	27-41	23-35	19-29
SPB / 5V	140-265	25-36	20-32	18-27	33-48	27-43	24-36
	265 & above	36-46	32-41	27-37	48-61	43-55	36-49
SPC	224-355	46-66	38-58	32-52	61-88	51-77	43-69
	355 & above	66-85	58-76	52-70	88-113	77-101	69-93
8V	335-520	81-107	68-90	56-73	108-143	91-120	75-97
	520 & above	107-167	90-140	73-113	143-223	120-187	97-151
CUT EDGE - CLASSICAL V-Belts							
ZX	40-100	5-7	5-6	3-5	6-9	6-8	5-6
	100 & above	7-10	7-8	6-7	9-14	9-11	8-9
AX	63-140	9-14	8-12	7-9	12-18	11-15	9-12
	140 & above	14-21	12-16	9-14	18-28	15-21	12-18
BX	90-200	18-28	15-22	12-18	25-37	20-29	15-25
	200 & above	28-40	22-33	18-28	37-54	29-44	25-37
CX	140-400	36-53	30-44	23-36	48-71	40-58	31-48
	400 & above	53-81	44-67	36-53	71-107	58-89	48-71
CUT EDGE - WEDGE / NARROW V-Belts							
XPZ / 3VX	56-95	9-14	8-12	7-10	12-18	11-15	9-14
	95 & above	14-20	12-18	10-16	18-26	15-25	14-21
XPA	71-140	16-23	14-20	12-16	21-31	18-26	15-21
	140 & above	23-36	20-30	16-25	31-48	26-40	21-34
XPB / 5VX	112-265	29-41	23-37	21-31	38-55	31-49	28-41
	265 & above	41-53	37-47	31-43	55-71	49-63	41-57
XPC	180-355	53-76	44-67	37-60	71-101	58-89	49-80
	355 & above	76-98	67-87	60-81	101-130	89-117	80-107
Note: Maximum Belt linear speed (Classical section: up to 30 m/sec, Wedge: up to 42 m/sec, Narrow: up to 45 m/sec)							

If you would require any additional information, please write an e-mail to us at info@pixtrans.com