



ABOUT (/ABOUT)

STOCKISTS ([HTTP://INDEX.WELDTITE.CO.UK/STOCKISTS](http://index.weldtite.co.uk/stockists))

EVENTS (/NEW-EVENTS)

NEWS (/NEWS)

HOW TO (/INSTRUCTIONS)

CAREERS (/CAREERS)

CONTACT (/CONTACT)

BLOG (/BLOG-LIST)

TUBELESS CONVERSION - A 10 STEP GUIDE TO GOING TUBELESS

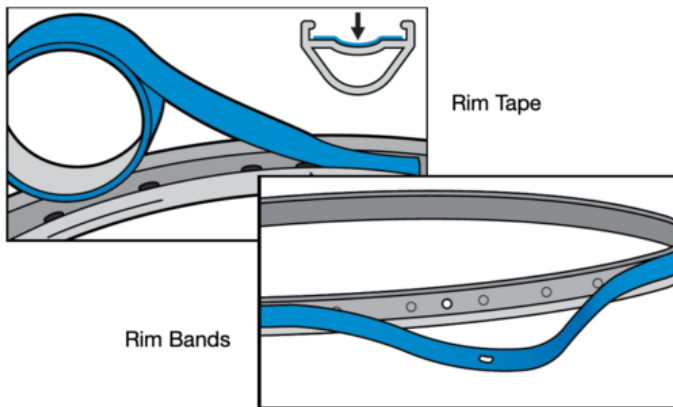

Step 1

After ensuring the rim is clean, fit Rim Tape or Easi-Fit Rim Bands to the rim bed of the wheel.

Skip to step 4 if using Easi-Fit Rim Bands.

Step 2

If using Rim Tape ensure a 10cm overlap of tape.

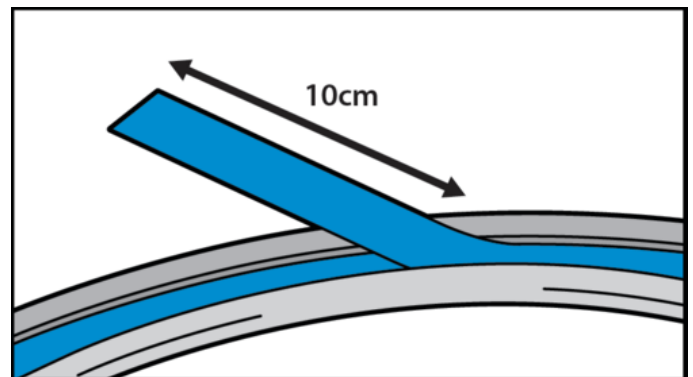

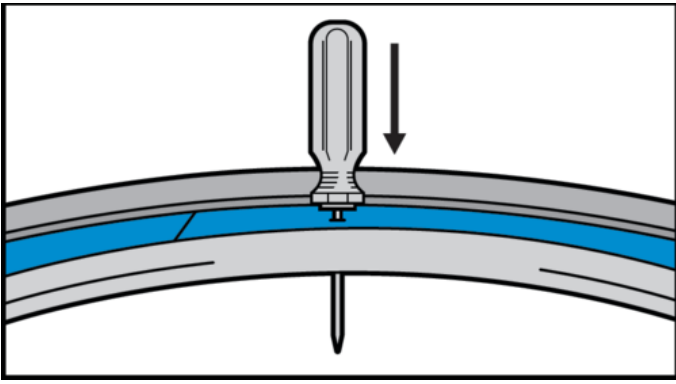

Step 3

Use a Phillips Screwdriver (the diameter of the valve hole) to create space for your valve in the Rim Tape.

Step 4

Insert Valve.

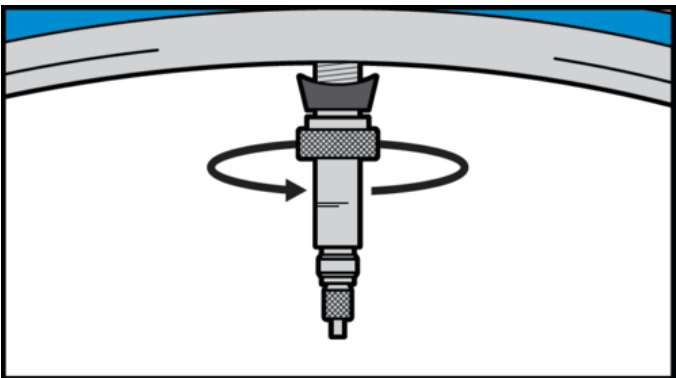
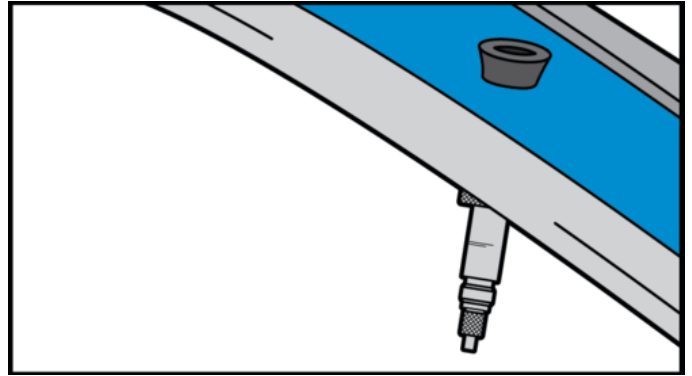

Step 5

Ensure airtight seal using the valve nut.

Step 6

Use Mounting Gel on the bead of your tyre to assist with tyre installation. Mount tyre onto wheel.

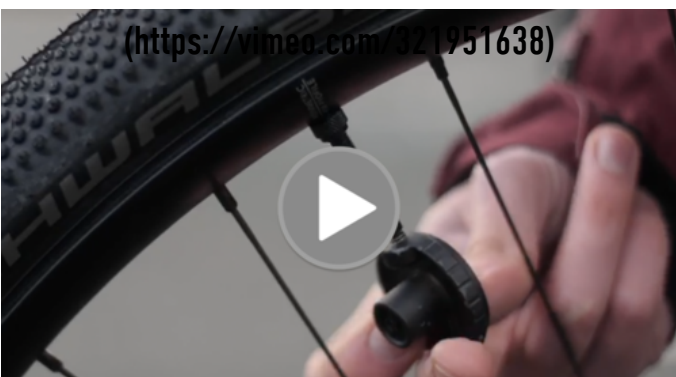
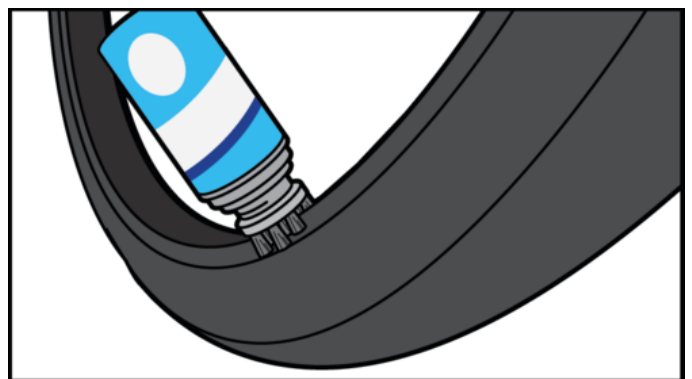

Step 7

Remove valve core using the integrated valve core removal tool for Schrader or Presta on the 240ml Tubeless Tyre Seal bottle.

Step 8

Fill your tyre with the recommended quantity of Weldtite Tubeless Tyre Sealant.

40ml = 700c x 18-23

60ml = 26"/700c 28-35

80ml = 27.5" / 650B

120ml = 29" / DH

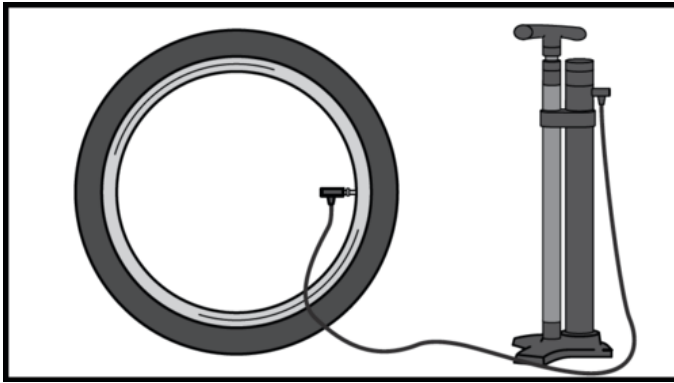
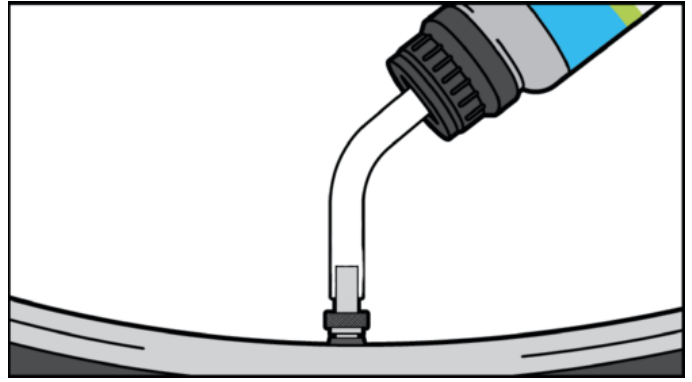

Step 9

Use a tubeless specific pump to fill your tyre with air. Ensure the tyre seats. Tip - listen for a 'popping' noise as your tyre seats.

Step 10

Rotate your wheel so the sealant can move around the tyre, ready to do it's job in the event of a puncture.

